

# FEEDTHROUGH SUPPRESSION CAPACITORS



**ALL RANGES ARE NOW RoHS COMPLIANT**

## CONTENTS

DC Feedthrough Capacitors – 10A	Page 2
DC Feedthrough Capacitors – 20A	Page 3
DC Feedthrough Capacitors – 100A	Page 4
AC Feedthrough Capacitors – 10A	Page 5
AC Feedthrough Capacitors – 20A	Page 6
AC Feedthrough Capacitors – 20A, 400Hz	Page 7
AC Feedthrough Capacitors – 100A	Page 8
AC Feedthrough Capacitors – 100A, 400Hz	Page 9
AC Feedthrough Capacitors – 100A to 500A	Page 10
Installation, Background, and Safety Information	Page 12



FM 00699

**MPE Limited**  
Hammond Road  
Knowsley Industrial Park  
Liverpool L33 7UL

# DC FEEDTHROUGH CAPACITORS – 10A



www.mpe.co.uk

## DESCRIPTION

A range of miniature dc feedthrough capacitors rated at 10A.

Capacitance values from 0.1µF to 1.5µF

Rated voltages from 30V dc to 400V dc  
RoHS compliant

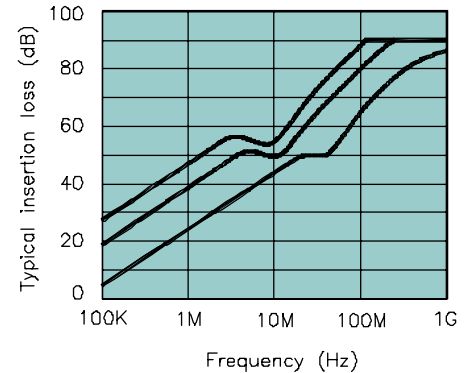

Performance examples      top      1.5µF  
   middle      0.6µF  
   bottom      0.1µF

## RATINGS AND CHARACTERISTICS

Rated Voltage	As tabulated
Test Voltage	Twice rated voltage
Rated Current, I <sub>R</sub>	10A @ 50°C*
Insulation Resistance	> 100MΩ
DC Resistance	< 2mΩ
Ambient Temperature Range	-55°C to +85°C
Climatic Category	55/85/21

\* Current derating between 50°C and 85°C

For temperature,  $\theta$      $I_{\theta} = I_R \sqrt{(85 - \theta)/35}$

## PRODUCT RANGE

Part Number	Capacitance Value (µF ±20%)	Voltage Rating (V dc)	FV Number **	Typical Insertion Loss (dB) in 50 Ω system with/without load							
				10 kHz	30 kHz	100 kHz	300 kHz	1 MHz	10 MHz	100 MHz	1 GHz
FC25172	0.1	400	FV1084128	-	1	5	14	24	44	70	84
FC25173	0.2	250	FV1084129	-	3	10	20	30	50	74	90
FC25174	0.3	160	FV1084130	-	5	14	24	34	50	74	90
FC25175	0.6	100	FV1084131	3	10	20	30	40	50	80	90
FC25176	0.9	63	FV1084132	5	13	23	33	43	51	83	90
FC25177	1.5	30	FV1084140	8	17	27	37	47	55	87	90

\*\* UK MOD fighting vehicle registration number

## DIMENSIONS AND MECHANICAL DETAILS

Dimensions in mm

Mounting hardware	8 A/F fixing nut and crinkle washer
Case	Nickel plated brass
Terminals	Nickel plated brass
Weight	5g
Tightening torque	Terminals 0.2Nm (use 2 spanners) Mounting thread 1Nm

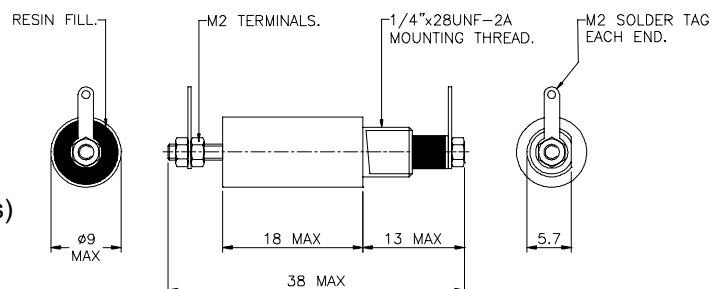

## DESCRIPTION

A range of dc feedthrough capacitors rated at 20A in a compact case size  
 Capacitance values from 0.8µF to 12µF  
 Rated voltages from 30V dc to 400V dc  
 RoHS compliant

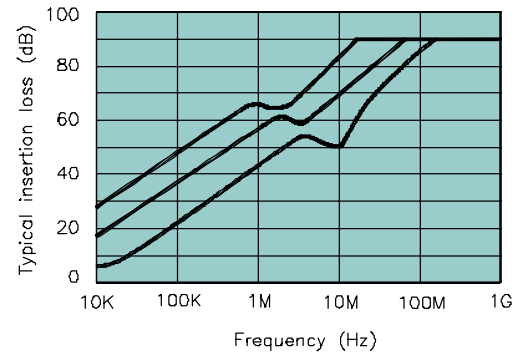

Performance examples      top      12µF  
    middle      4µF  
    bottom      0.8µF

## RATINGS AND CHARACTERISTICS

Rated Voltage	As tabulated
Test Voltage	Twice rated voltage
Rated Current, I <sub>R</sub>	20A @ 50°C*
Insulation Resistance	> 100MΩ
DC Resistance	< 1mΩ
Ambient Temperature Range	-55°C to +85°C
Climatic Category	55/85/21
*Current derating between 50°C and 85°C	For temperature, $\theta$ $I_{\theta} = I_R \sqrt{(85 - \theta)/35}$

## PRODUCT RANGE

Part Number	Capacitance Value (µF ±20%)	Voltage Rating (V dc)	Typical Insertion Loss (dB) in 50 Ω system with/without load							
			10 kHz	30 kHz	100 kHz	300 kHz	1 MHz	10 MHz	100 MHz	1 GHz
FC23646	0.8	400	4	12	22	32	42	51	82	90
FC23647	1	250	5	14	24	34	44	52	84	90
FC23648	2	160	10	20	30	40	50	58	90	90
FC23649	4	100	16	26	36	46	56	70	90	90
FC23650	5	80	18	28	38	48	58	74	90	90
FC23651	7	63	21	31	41	51	60	79	90	90
FC23652	12	30	26	36	46	56	62	86	90	90

## DIMENSIONS AND MECHANICAL DETAILS

Dimensions in mm

Mounting hardware	19 A/F fixing nut and washer
Case	Nickel plated brass
Terminals	Nickel plated brass
Weight	25g
Max tightening torque:	
Terminals	0.5Nm (use 2 spanners)
Mounting thread	7Nm

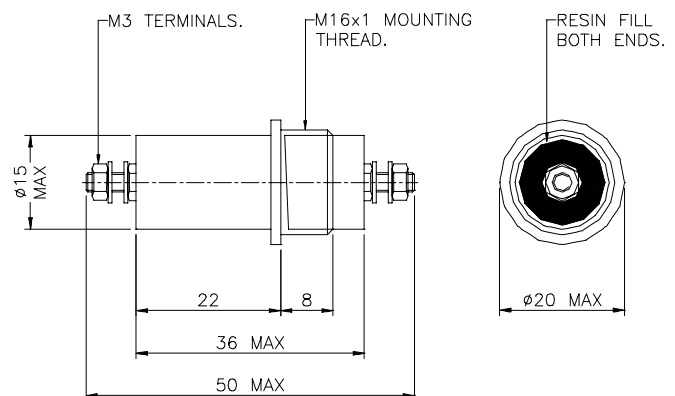

# DC FEEDTHROUGH CAPACITORS – 100A



## DESCRIPTION

A range of dc feedthrough capacitors rated at 100A  
 Capacitance values from 0.8µF to 12µF  
 Rated voltages from 30V dc to 400V dc  
 RoHS compliant

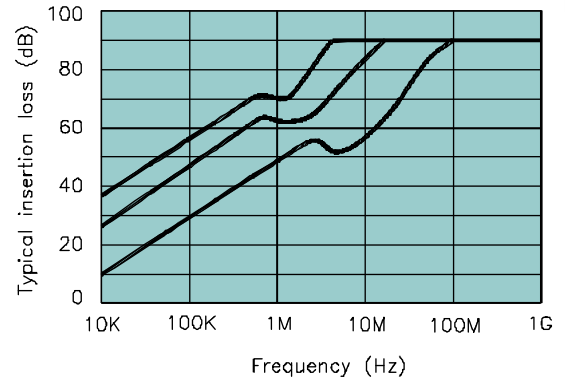

Performance examples      top      40µF  
    middle      14µF  
    bottom      2µF

## RATINGS AND CHARACTERISTICS

Rated Voltage	As tabulated
Test Voltage	Twice rated voltage
Rated Current, I <sub>R</sub>	100A @ 50°C*
Insulation Resistance	> 100MΩ
DC Resistance	< 0.5mΩ
Ambient Temperature Range	-55°C to +85°C
Climatic Category	55/85/21

\*Current derating between 50°C and 85°C

$$\text{For temperature, } \theta \quad I_{\theta} = I_R \sqrt{(85 - \theta) / 35}$$

## PRODUCT RANGE

Part Number	Capacitance Value (µF ±20%)	Voltage Rating (V dc)	FV Number **	Typical Insertion Loss (dB) in 50 Ω system with/without load							
				10 kHz	30 kHz	100 kHz	300 kHz	1 MHz	10 MHz	100 MHz	1 GHz
FC25186	2	400	FV1084133	10	20	30	40	50	58	90	90
FC25187	4	250	FV1084134	16	26	36	46	56	70	90	90
FC25188	6	160	FV1084135	20	30	40	50	60	77	90	90
FC25189	14	100	FV1084136	27	37	47	57	63	87	90	90
FC25190	18	80	FV1084137	29	39	49	59	66	90	90	90
FC25191	25	63	FV1084138	32	42	52	62	66	90	90	90
FC25192	40	30	FV1084141	36	46	56	66	66	90	90	90

\*\* UK MOD fighting vehicle registration number

## DIMENSIONS AND MECHANICAL DETAILS

Dimensions in mm

Mounting hardware	30 A/F fixing nut and washer
Case	Nickel plated brass
Terminals	Nickel plated brass
Weight	120g
Max tightening torque:	
Terminals	2.5Nm (use 2 spanners)
Mounting thread	14Nm

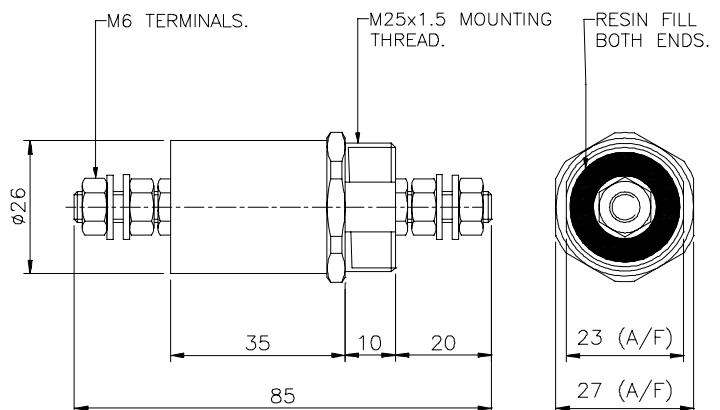

# AC FEEDTHROUGH CAPACITORS – 10A



www.mpe.co.uk

## DESCRIPTION

A range of miniature ac feedthrough capacitors rated at 10A  
 Capacitance values from 1.3nF to 4.7nF  
 Test voltage is 2250V dc  
 RoHS compliant

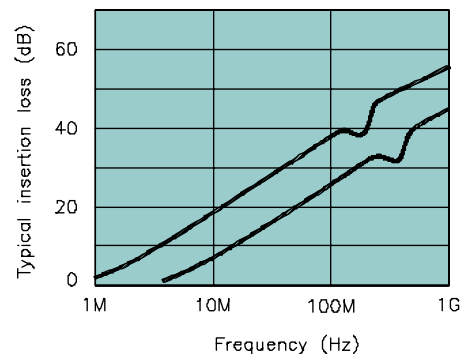

Performance examples      top      4.7nF  
    bottom      1.3nF

## RATINGS AND CHARACTERISTICS

Rated Voltage	250V 50/60Hz, or 600V dc
Test Voltage	2250V dc
Rated Current, I <sub>R</sub>	10A @ 50°C*
Insulation Resistance	> 100MΩ
DC Resistance	< 2mΩ
Ambient Temperature Range	-55°C to +85°C
Climatic Category	55/85/21

\*Current derating between 50°C and 85°C      For temperature,  $I_{\theta} = I_R \sqrt{(85 - \theta)/35}$

## PRODUCT RANGE

Part Number	Capacitance Value (nF ±20%)	Test Voltage (V dc)	Max Leakage Current (mA) @ 250V 50Hz	Typical Insertion Loss (dB) in 50 Ω system with/without load				
				10 MHz	30 MHz	100 MHz	300 MHz	1 GHz
FC23725	1.3	2250	0.12	7	16	26	36	46
FC23726	3.3	2250	0.31	14	24	34	44	54
FC23727	4.7	2250	0.45	17	27	37	47	57

## DIMENSIONS AND MECHANICAL DETAILS

Dimensions in mm

Mounting hardware	8 A/F fixing nut and crinkle washer
Case	Nickel plated brass
Terminals	Nickel plated brass
Weight	5g
Tightening torque	Terminals 0.2Nm (use 2 spanners) Mounting thread 1Nm

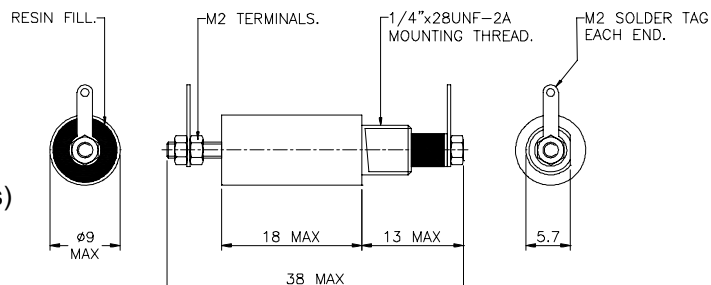

## DESCRIPTION

A range of ac feedthrough capacitors rated at 20A in a compact case size  
 Capacitance values from 5nF to 300nF  
 Test voltages of either 1250V dc or 2250V dc are offered  
 RoHS compliant

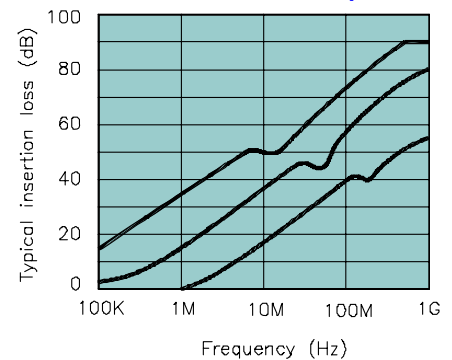

Performance examples  
 top 300nF  
 middle 50nF  
 bottom 5nF

## RATINGS AND CHARACTERISTICS

Rated Voltage	250V ac 50/60Hz, or 600V dc
Test Voltage	As tabulated
Rated Current, I <sub>R</sub>	20A @ 50°C
Insulation Resistance	> 100MΩ
DC Resistance	< 1mΩ
Ambient Temperature Range	-55°C to +85°C
Climatic Category	55/85/21

\*Current derating between 50°C and 85°C

$$\text{For temperature, } \theta \quad I_{\theta} = I_R \sqrt{(85 - \theta) / 35}$$

## PRODUCT RANGE

Part Number	Capacitance Value (nF ±20%)	Test Voltage (V dc)	Max Leakage Current (mA) @ 250V 50Hz	Typical Insertion Loss (dB) in 50 Ω system with/without load					
				300 kHz	1 MHz	10 MHz	100 MHz	300 MHz	1 GHz
FC23684	5	2250	0.5	-	2	17	37	47	57
FC23685	10	2250	1	1	6	24	44	54	64
FC23686	20	2250	1.9	3	10	30	46	60	70
FC23687	50	2250	4.7	8	18	38	58	68	78
FC23688	80	2250	7.5	12	22	42	62	72	82
FC23689	100	1250	9.4	14	24	44	70	74	84
FC23690	200	1250	19	20	30	50	74	80	90
FC23691	300	1250	28	24	34	50	74	84	90

## DIMENSIONS AND MECHANICAL DETAILS

Dimensions in mm

Mounting hardware	19 A/F fixing nut and washer
Case	Nickel plated brass
Terminals	Nickel plated brass
Weight	25g
Max tightening torque:	
Terminals	0.5Nm (use 2 spanners)
Mounting thread	7Nm

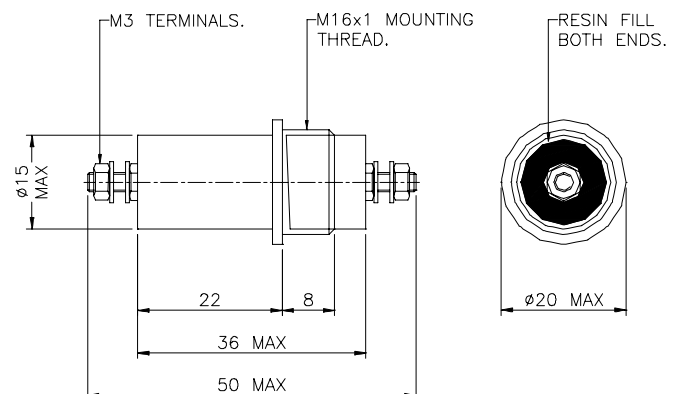

# AC FEEDTHROUGH CAPACITORS – 20A 400Hz



www.mpe.co.uk

## DESCRIPTION

A range of 115V 400Hz ac feedthrough capacitors rated at 20A in a compact case size  
 Capacitance values from 100nF to 250nF  
 Test voltage is 1250V dc  
 RoHS compliant

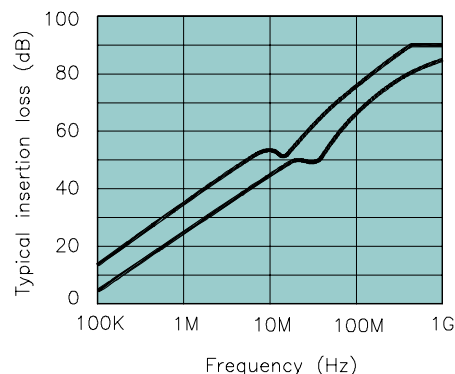

Performance examples      top      250nF  
    bottom      100nF

## RATINGS AND CHARACTERISTICS

Rated Voltage	115V 400Hz, or 250V ac 50/60Hz, or 600V dc
Test Voltage	1250V dc
Rated Current, $I_R$	20A @ 50°C*
Insulation Resistance	> 100MΩ
DC Resistance	< 1mΩ
Ambient Temperature Range	-55°C to +70°C
Climatic Category	55/70/21

\*Current derating between 50°C and 70°C

$$\text{For temperature, } \theta \quad I_\theta = I_R \sqrt{(70 - \theta) / 20}$$

## PRODUCT RANGE

Part Number	Capacitance Value (nF ±20%)	Test Voltage (V dc)	Max Leakage Current (mA) @ 115V 400Hz	Typical Insertion Loss (dB) in 50 Ω system with/without load					
				300 kHz	1 MHz	10 MHz	100 MHz	300 MHz	1 GHz
FC25840	100	1250	35	14	24	44	70	74	84
FC25841	200	1250	70	20	30	50	74	80	90
FC25842	250	1250	87	22	32	50	74	82	90

## DIMENSIONS AND MECHANICAL DETAILS

Dimensions in mm

Mounting hardware	19 A/F fixing nut and washer
Case	Nickel plated brass
Terminals	Nickel plated brass
Weight	25g
Max tightening torque:	
Terminals	0.5Nm (use 2 spanners)
Mounting thread	7Nm

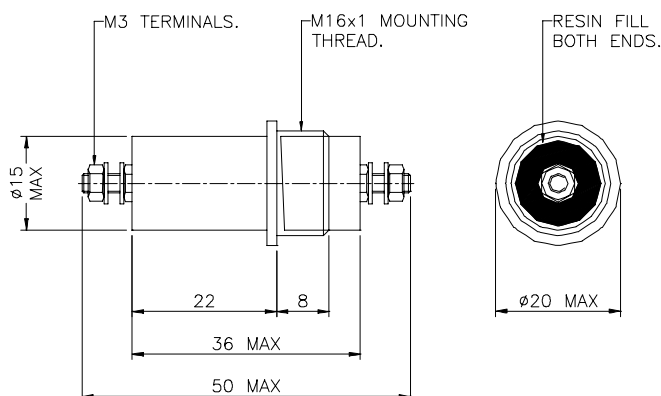

# AC FEEDTHROUGH CAPACITORS – 100A



www.mpe.co.uk

## DESCRIPTION

A range of ac feedthrough capacitors rated at 100A  
 Capacitance values from 0.1µF to 1µF  
 Test voltages of either 1250V dc or 2250V dc are offered  
 RoHS compliant

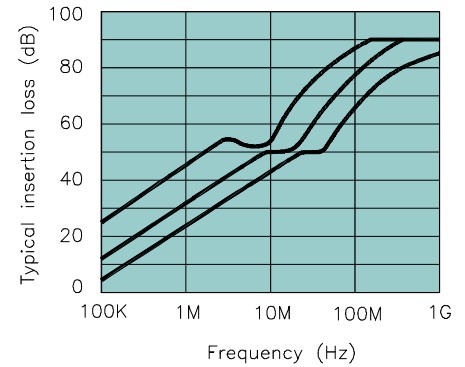

Performance examples      top      1000nF  
    middle      250nF  
    bottom      100nF

## RATINGS AND CHARACTERISTICS

Rated Voltage	250V 50/60Hz, or 600V dc
Test Voltage	As tabulated
Rated Current, I <sub>R</sub>	100A @ 50°C*
Insulation Resistance	> 100MΩ
DC Resistance	< 0.5mΩ
Ambient Temperature Range	-55°C to +85°C
Climatic Category	55/85/21

\*Current derating between 50°C and 85°C

$$\text{For temperature, } \theta \quad I_{\theta} = I_R \sqrt{(85 - \theta) / 35}$$

## PRODUCT RANGE

Part Number	Capacitance Value (nF ±20%)	Test Voltage (V dc)	Max Leakage Current (mA) @ 250V 50Hz	Typical Insertion Loss (dB) in 50 Ω system with/without load					
				100 kHz	300 kHz	1 MHz	10 MHz	100 MHz	1 GHz
FC25180	100	2250	9.4	5	14	24	44	70	84
FC25181	200	2250	19	10	20	30	50	74	90
FC25182	250	2250	24	12	22	32	50	74	90
FC25183	500	1250	47	18	28	38	50	78	90
FC25184	1000	1250	94	24	34	44	52	84	90

## DIMENSIONS AND MECHANICAL DETAILS

Dimensions in mm

Mounting hardware	30 A/F fixing nut and washer
Case	Nickel plated brass
Terminals	Nickel plated brass
Weight	120g
Max tightening torque:	
Terminals	2.5Nm (use 2 spanners)
Mounting thread	14Nm

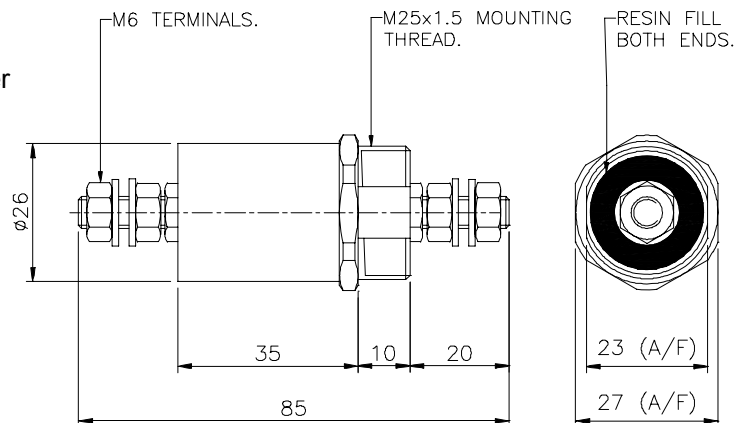

# AC FEEDTHROUGH CAPACITORS – 100A 400Hz



www.mpe.co.uk

## DESCRIPTION

A range of 115V 400Hz feedthrough capacitors rated at 100A  
 Capacitance values from 0.3µF to 1µF  
 Test voltage is 1250V dc  
 RoHS compliant

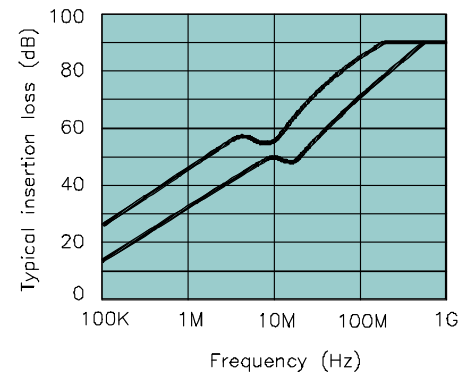

Performance examples top 1000nF  
 Bottom 300nF

## RATINGS AND CHARACTERISTICS

Rated Voltage	115V 400Hz, or 250V ac 50/60Hz, or 600V dc
Test Voltage	1250V dc
Rated Current, I <sub>R</sub>	100A @ 50°C*
Insulation Resistance	> 100MΩ
DC Resistance	< 0.5mΩ
Ambient Temperature Range	-55°C to +70°C
Climatic Category	55/70/21

\*Current derating between 50°C and 70°C

$$\text{For temperature, } \theta \quad I_{\theta} = I_R \sqrt{(70 - \theta) / 20}$$

## PRODUCT RANGE

Part Number	Capacitance Value (nF ±20%)	Test Voltage (V dc)	Max Leakage Current (mA) @ 115V 400Hz	Typical Insertion Loss (dB) in 50 Ω system with/without load					
				100 kHz	300 kHz	1 MHz	10 MHz	100 MHz	1 GHz
FC25844	300	1250	104	14	24	34	50	74	90
FC25845	500	1250	174	18	28	38	50	78	90
FC25846	1000	1250	347	24	34	44	52	84	90

## DIMENSIONS AND MECHANICAL DETAILS

Dimensions in mm

Mounting hardware	30 A/F fixing nut and washer
Case	Nickel plated brass
Terminals	Nickel plated brass
Weight	120g
Max tightening torque:	
Terminals	2.5Nm (use 2 spanners)
Mounting thread	14Nm

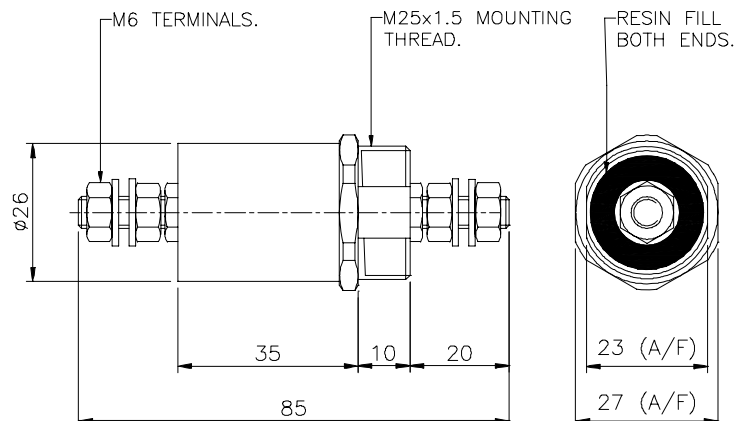

# AC FEEDTHROUGH CAPACITORS – 100A – 500A



www.mpe.co.uk

## DESCRIPTION

A range of high current ac feedthrough capacitors rated at 100A – 500A  
 Capacitance values from 5µF to 15µF  
 Test voltage is 1500V dc  
 This range of capacitors has built-in discharge resistors for safety  
 RoHS compliant



Performance examples top 15µF bottom 5µF

## RATINGS AND CHARACTERISTICS

Rated Voltage	250V 50/60Hz, or 115V 400Hz, or 1000V dc
Test Voltage	1500V dc
Rated Current	As tabulated
Insulation Resistance	>100MΩ (prior to fitting discharge resistors)
Discharge resistance	600kΩ
Discharge time	<30s to below 34V
DC Resistance	As tabulated
Ambient Temperature Range	-55°C to +70°C
Climatic Category	55/70/21

## PRODUCT RANGE

Part Number	Capacitance Value (µF ±20%)	Rated Current I <sub>R</sub> (A) @ 40°C	Max Leakage Current (mA) @ 250V 50Hz	Typical Insertion Loss (dB) in 50 Ω system with/without load							
				10 kHz	30 kHz	100 kHz	300 kHz	1 MHz	10 MHz	100 MHz	1 GHz
FC25151	5	100	470	18	28	38	48	58	74	90	90
FC25152	10	100	940	24	34	44	54	61	83	90	90
FC25153	15	100	1410	27	37	47	57	64	87	90	90
FC25156	5	200	470	18	28	38	48	58	74	90	90
FC25157	10	200	940	24	34	44	54	61	83	90	90
FC25158	15	200	1410	27	37	47	57	64	87	90	90
FC25160	5	300	470	18	28	38	48	58	74	90	90
FC25161	10	300	940	24	34	44	54	61	83	90	90
FC25162	15	300	1410	27	37	47	57	64	87	90	90
FC25165	5	500	470	18	28	38	48	58	74	90	90
FC25166	10	500	940	24	34	44	54	61	83	90	90
FC25167	15	500	1410	27	37	47	57	64	87	90	90

Current derating between 40°C and 70°C

$$\text{For temperature, } \theta \quad I_{\theta} = I_R \sqrt{(70 - \theta) / 30}$$

# AC FEEDTHROUGH CAPACITORS – 100A – 500A



www.mpe.co.uk

## DIMENSIONS AND MECHANICAL DETAILS

Dimensions in mm

Mounting hardware  
Case material  
Max tightening torque:  
Terminal thread  
Fixing studs

Supplied with M6 fixing nuts and washers  
Tin plated brass or steel, paint finish

As tabulated (use 2 spanners)  
2.5Nm

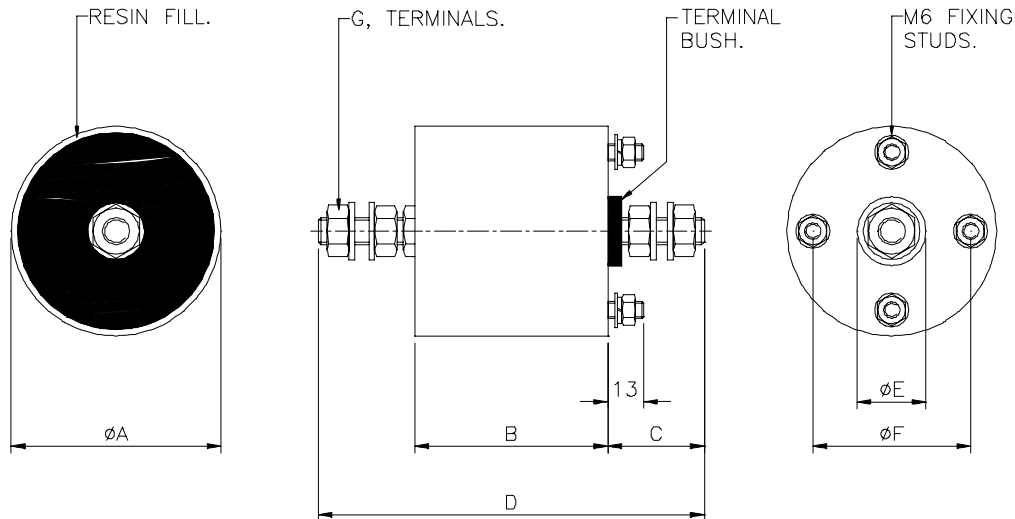

Part Number	A	B	C	D	E	F p.c.d.	G Thread	Max torque on G (Nm)	Weight (g)
FC25151	76	70	25	120	25	57.2	M6	2.5	900
FC25152	76	70	25	120	25	57.2	M6	2.5	900
FC25123	95	70	25	120	25	76.2	M6	2.5	1400
FC25156	76	70	35	140	25	57.2	M10	8	900
FC25157	76	70	35	140	25	57.2	M10	8	900
FC25158	95	70	35	140	25	76.2	M10	8	1400
FC25160	76	70	40	150	32	57.2	M12	11	900
FC25161	76	70	40	150	32	57.2	M12	11	900
FC25162	95	70	40	150	32	76.2	M12	11	1400
FC25165	76	70	50	170	32	57.2	M16	20	900
FC25166	95	70	50	170	32	76.2	M16	20	1400
FC25167	95	70	50	170	32	76.2	M16	20	1400

## INSTALLATION

This range of capacitors should be securely mounted to the bulkhead by means of the four fixing studs in the base mounting plate. The base of the capacitor is left unpainted to ensure a good electrical interface with the bulkhead.

## INSTALLATION GUIDELINES

Feedthrough capacitors are designed for through-bulkhead mounting for offering high frequency filtering in line to ground applications. They should be mounted through a metal bulkhead or chassis.

The bulkhead mounting surface should be clean and unpainted to offer a low impedance path from the capacitor to the equipment chassis. Poor earth bonding will limit the available performance of the product and could compromise safety.

Conductive paint finishes should be avoided as they do not usually provide adequate conductivity.

2 spanners should be used when making electrical connections to the terminals, and maximum tightening torque figures quoted should be observed.

## CONSTRUCTION AND RELIABILITY

MPE have been designing and manufacturing feedthrough capacitors and filters for more than 40 years, and plastic film feedthrough capacitors for more than 25 years. MPE has always been at the forefront of the design of feedthrough capacitors and the improvements in materials and assembly techniques, which have evolved over the years, have been incorporated into these ranges of feedthrough capacitors.

The designs covered by this catalogue all utilise self-healing metallised plastic film capacitor material and incorporate a solderless capacitor assembly technique to avoid heat damage to the plastic dielectric material, which would reduce its life and reliability. Terminals are nickel plated for good conductivity.

## FEEDTHROUGH CAPACITOR PERFORMANCE

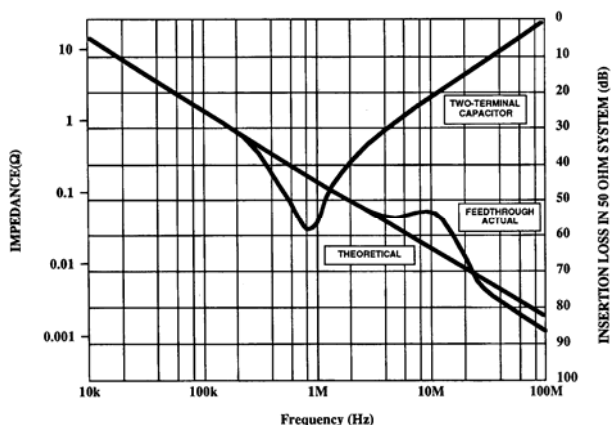

- Normal two-terminal capacitors resonate with their lead inductance in the region 1-10MHz
- This limits their use as suppression components above a few MHz
- Feedthrough capacitors have no major resonance as they have no lead inductance
- Their performance continues to increase with frequency
- Hence feedthrough capacitors are essential for good high frequency performance
- As an example this graph compares the performance of a 1 $\mu$ F feedthrough capacitor with a 1 $\mu$ F two-terminal capacitor

## SAFETY

Relevant safety standards have been adhered to in the design and manufacture of these products. However, all capacitors will store charge after power has been removed and must be treated with respect as this can be lethal when the voltage and charge are high enough. Except for the range on page 10, the capacitors contained within this catalogue do not contain internal discharge resistors. It is therefore recommended that they are fitted with external discharge resistors or other means to discharge the capacitors after the power has been removed. Where necessary, terminals should be enclosed by the user to prevent any danger of electric shock or accidental shorting.

In all cases, capacitors should always be shorted to earth prior to touching to ensure they are fully discharged.

The user should ensure he is familiar with restrictions on capacitance value, earth leakage current, test voltage, and safety labelling requirements, which may be applicable to his particular installation.

In particular, safety standards IEC950 and EN60950, which most electrical equipment needs to comply with, contain a number of specific requirements for equipment incorporating capacitors, which may be applicable.

## CUSTOM DESIGNS

MPE offers a rapid design service for custom designs where special packaging, mounting, terminations, or multiple lines are required. Over 50% of the feedthrough components manufactured by MPE are custom designs and this can offer a very cost effective installation solution. Please ask to see examples of previously offered solutions.

## FURTHER INFORMATION

For more detailed technical background information, and application notes detailing the benefits of feedthrough capacitors over traditional capacitors, please contact the factory.